

**EML4551-2**

# Design Review 5

## Team 506

### MeWee Table

---

March 3, 2020

Alec Ellis, Kyle Innis, Anthony Muniz,  
Rieley O'Brien, Lauren Smith

# Team Introductions



**Alec Ellis**

Project Manager &  
Human Factors Engineer



**Kyle Innis**

Geometric Integration  
Engineer



**Anthony Muniz**

Mechanical Systems  
Engineer



**Rieley O'Brien**

Systems Engineer



**Lauren Smith**

Materials Science  
Engineer

# Sponsor

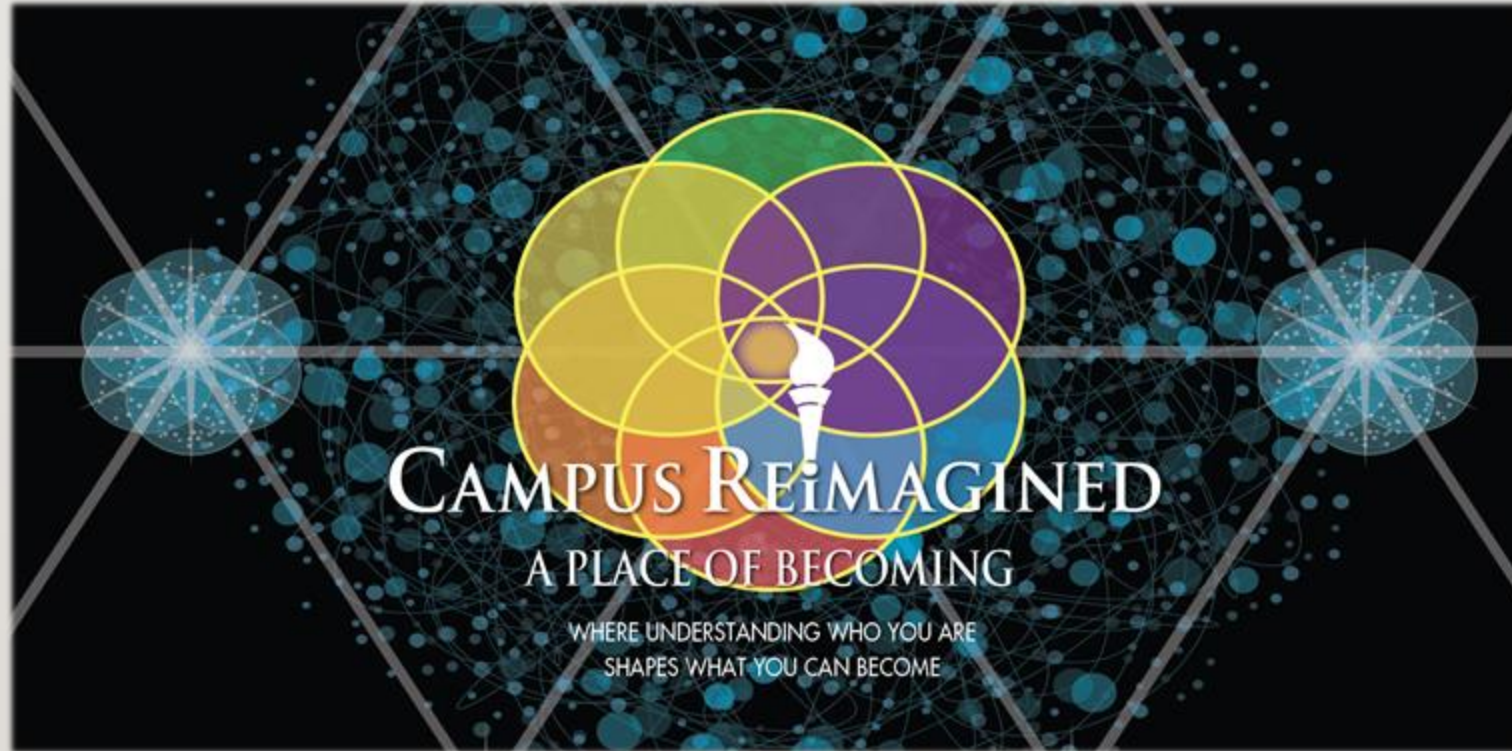

Rieley O'Brien

# Advisor, Visionary & Point of Contact



Dr. Patrick Hollis  
FAMU-FSU College of  
Engineering



Mr. Bill Lindner  
Campus Reimagined (CRI)



Mr. Peter Butler  
Campus Reimagined (CRI)

Rieley O'Brien

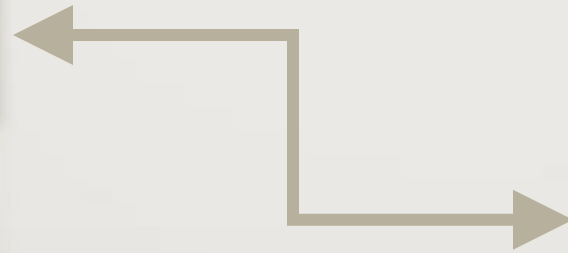

# Objective

- To design and build a multipurpose table allowing for collaborative work and individual work which will eliminate unused space in university libraries

Rieley O'Brien



Rieley O'Brien





Rieley O'Brien



# Everyone's Problem

- We have all been to a location that did not have enough seats or had inefficient use of the available space
  - For us students it is the libraries, where thousands of students go to get assignments done, and usually there isn't enough space
  - For others this is going to a coffee shop and there is not a place to sit because it's odd to share tables with strangers

Rieley O'Brien



# Project Background

- Tables are the primary object that people use to do work on and collaborate with others
- University libraries have limited table space with some tables only having one to two people sitting at them
- A specific table design is needed to reduce unutilized space and increase work efficiently



Rieley O'Brien

# Libraries Are for Studying

- Gensler research found that libraries rank highest for both individual and group study, above these others:
  - Dorm/apartment, lounge, café, outdoors, lab space, classroom
- Avg. **13.5** hours/week **alone** vs. **4.3** hours/week **collaborative/group**
- Highest performing students count on libraries for a peaceful, isolated study environment



*Gensler Research Catalogue, 2017, p. 90-93*

Rieley O'Brien

# Customer Needs

Question	Customer Statement	Interpreted Need
What is the most concerning factor for the design?	The design must be safe and simple.	Our top design priorities are safety and simplicity.
Does the table have an electric element to it?	The table should have outlets and phone ports to charge items.	The design can include a power source that charges people's electronic items.
Who is our primary and secondary market?	The table is being built for CRI for use in the university library but use anywhere work can be done would be beneficial.	The primary market is University libraries and the secondary market is coffee shops or office buildings.
What are we hoping to accomplish with the design?	The idea for this table came from observing students who waste available space; sitting by themselves at a multi-person table.	The table will increase the amount of utilized space when compared to a traditional table.
Can the table be any shape?	Yes, circular tables have already been used for the conceptual idea, but any shape and size are allowed.	The table can be any geometric shape, but more research is needed to find optimal design.
Does the table have to be stationary or mobile?	The table does not need to be mobile, but the easier it folds and moves, the better.	The table allows for simple relocation.
Is there a specific age range for our market?	College Students	The age of the users ranges from 17-25.

- The primary customer needs are simplicity and increasing usable space
- The table needs to be transportable and compactable

Rieley O'Brien

# Functional Decomposition

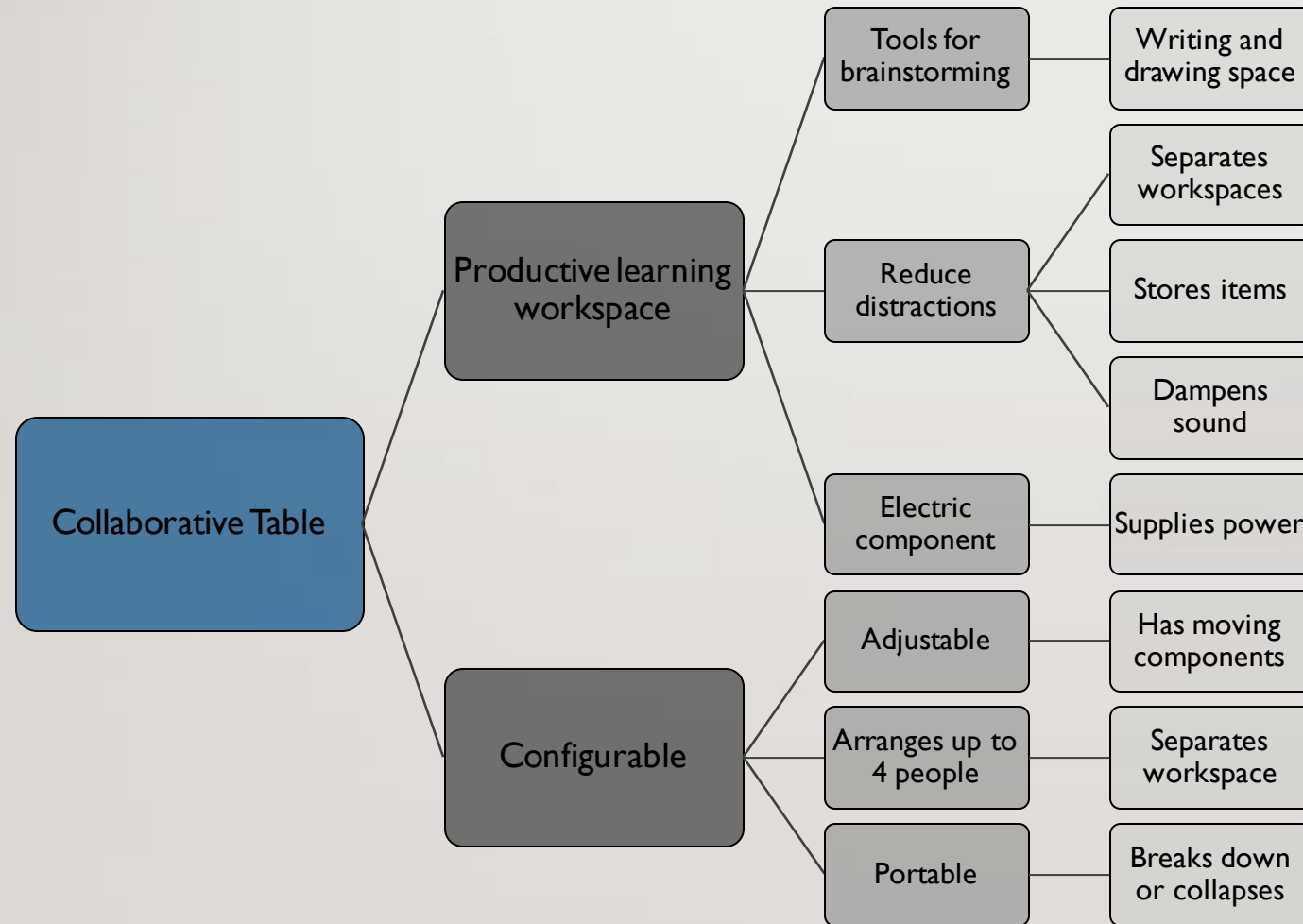

- Important functions are configurable and separates workspace
- Actions of the table are supplying power, providing a writing space, and being able to move and store easily

Rieley O'Brien

# Concept Generation

- Morphological chart, biomimicry, and classification of medium & high-fidelity concepts were used

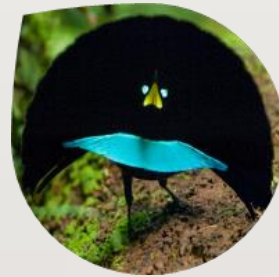

Reducing unused workspace	Provides individual workspace	Provides group workspace	Supports work tools	Reduces distractions
Portable with wheels	Multiple dividers that create 4 sections	Dividers can be taken off	Power supply to charge items	Sound dampening
Adjustable with moving components	People at the table have to push a button to detach a divider	Parts of the table extend for someone to use	Whiteboard	Storage space to place phones
Expandable with additional components	A section of the table can be removable	Table can change shape to account for different people	Measuring tools	Desk dividers that surround people

Anthony Muniz

# Concept Selection

- This was followed by a lengthy selection process:
1. Binary Pairwise
  2. House of Quality
  3. Pugh Chart
  4. Analytical Hierarchy Process

Relative Weight	Customer Importance	Customer Requirements	Functional Requirements										
			Direction of Improvement	Writing/drawing space integration	Time to setup table	Power integration	Workspace size	Time to divide workspace	Ease of transportation	Sound dampening	Injury risks	Ability to store items	Consensus of table design
26%	5	Functionality	●	▽	●	●	○	▽	○	▽	●	▽	▽
21%	4	User's Simplicity	▽	●	▽	▽	●	○	▽	●	▽	○	▽
5%	1	Safety	▽	▽	▽	▽	▽	▽	▽	●	▽	▽	▽
16%	3	Compactability	▽	●	▽	○	○	●	▽	▽	▽	▽	▽
11%	2	Aesthetics	▽	▽	▽	▽	▽	▽	▽	▽	▽	●	▽
11%	2	Cost	○	▽	●	○	▽	▽	○	▽	○	▽	●
11%	2	Weight	○	▽	○	●	▽	▽	○	▽	○	▽	○
Importance Rating Sum (Importance			352.63	395	416	447	353	268	195	311	353	226	205.3
Relative Weight			11%	12%	13%	13%	11%	8%	6%	9%	11%	7%	6%

Anthony Muniz

# Design

- Retractable whiteboard that's default state is upward, separating people
- Legs will lock open at 90° for ease of table setup
- Whiteboards will lock in the down position and be spring loaded for raising with less effort



Anthony Muniz

# Design

- Tabletops will be locked into place

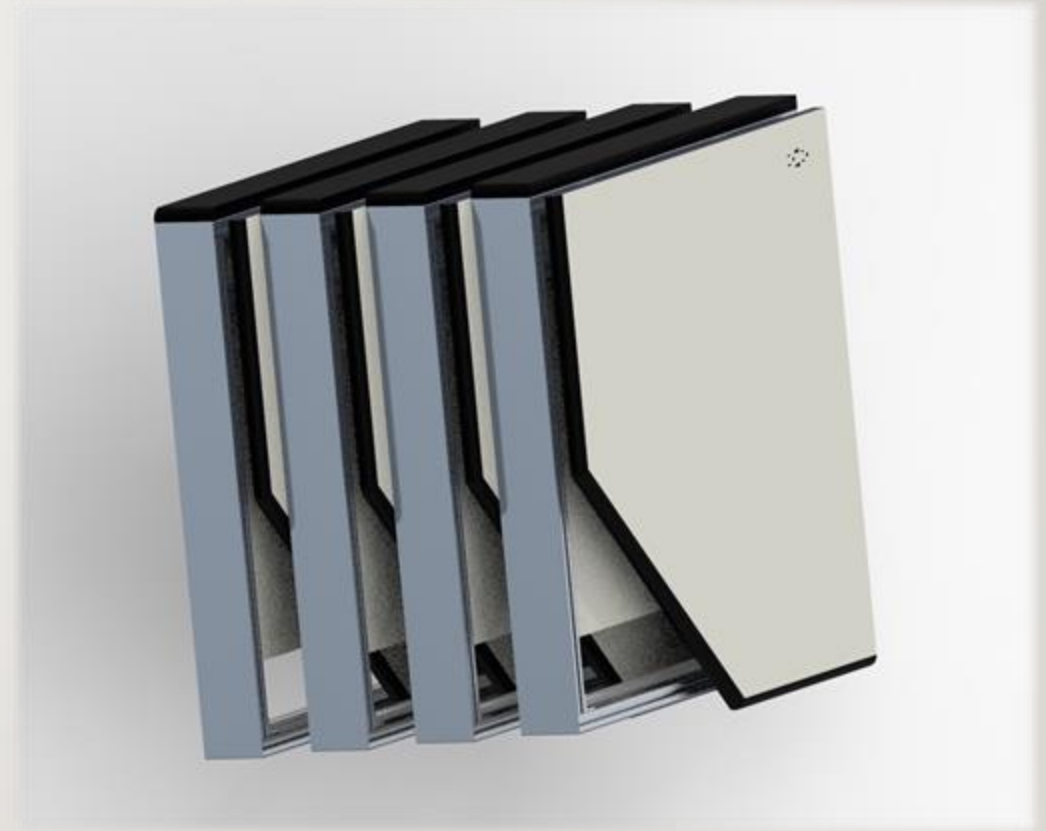

- Table folds to roughly 30”x30”x20” and is equipped with 8 total caster wheels for transport

Anthony Muniz



# Design

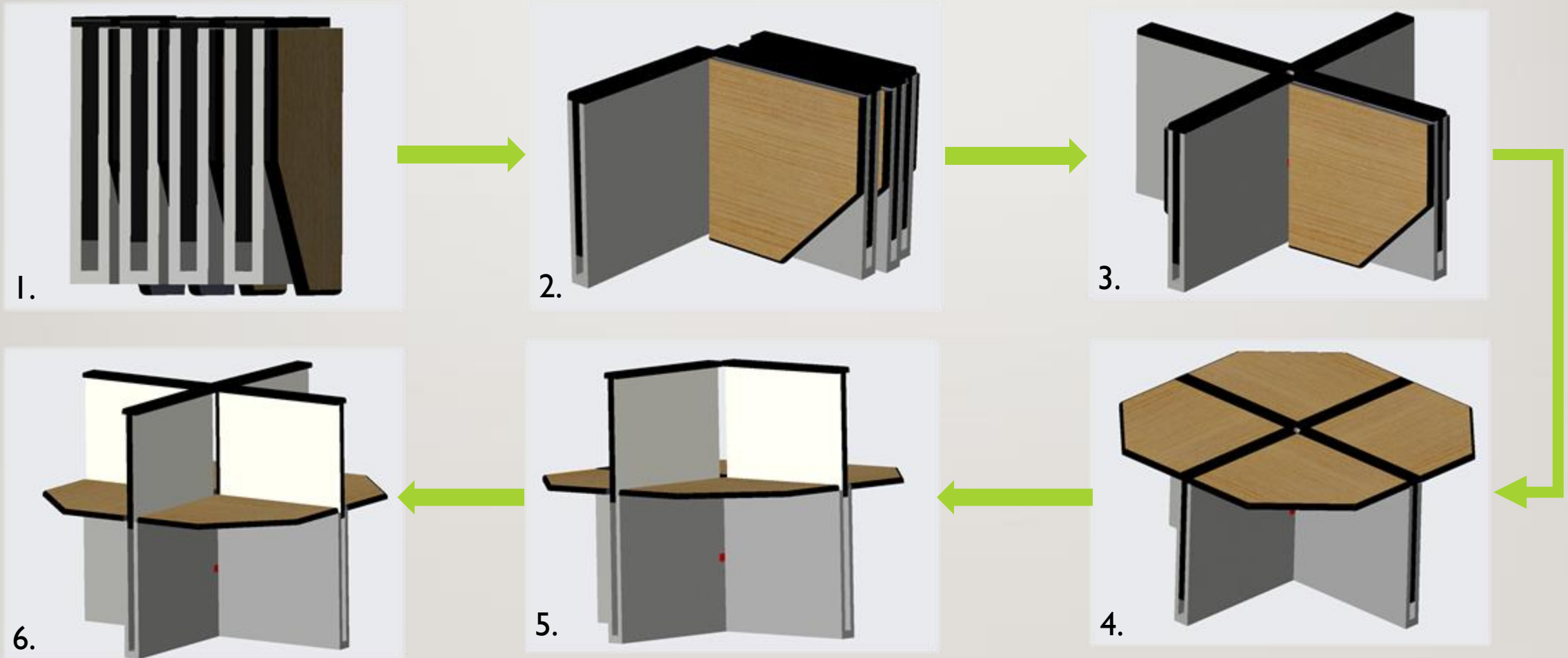

Anthony Muniz

# Scaled Prototype

- To observe the main features of the table, a scaled down prototype was created
- Displays the dividers and separate tabletops for each section
- Incorporates the collapse feature of the table



Anthony Muniz

# Full-size Model

- Constructed from plywood and is heavy
- Demonstrates a quarter of the actual table (2 legs, 1 tabletop)
- Used to determine:
  - A locking mechanism to hold up the tabletops
  - Best way to stop the legs from swiveling open past 90°



Anthony Muniz

# Full-size Model

- Model aided in determining function of:
  - Mechanism for raising the whiteboards
  - Hinges with a 90° stop for legs
  - Correct size of 360° rotation caster wheels
  - Support pins for tabletops once open



Anthony Muniz

# Construction Frame

## 80/20 Framing Extrusion

- Provides T-Slot aluminum profiles with channels used to connect other bars and parts
- Used to create custom solutions
- Adjustments and assembly are fast, no welding required

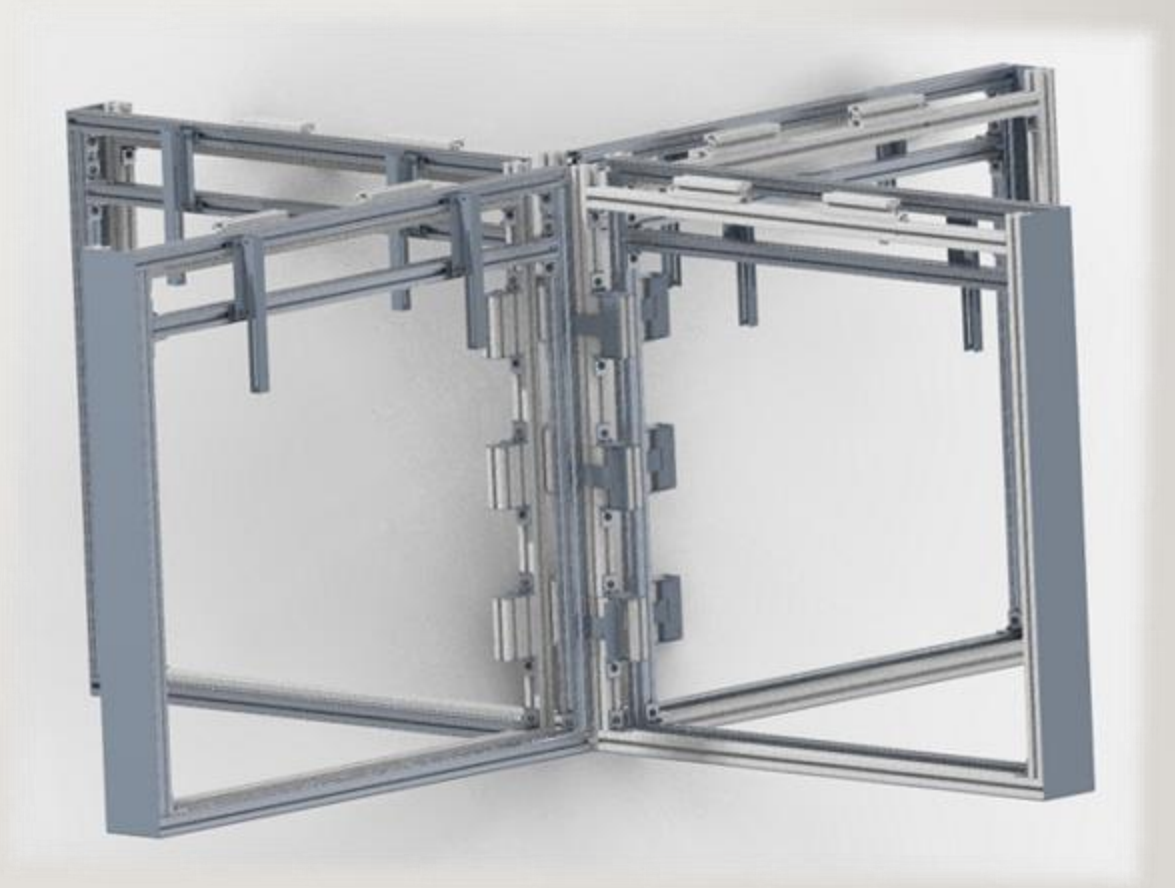

Lauren Smith

# Construction Tabletop

## MDF Melamine Board

- MDF does not expand or contract in humid environments
- Very minimal swelling if it gets wet
- The density of MDF accepts hinges and screws better than more porous wood, creating a stronger hold
- Priced lower than other wood species
- density is consistent throughout, so cut edges appear smooth and won't have voids or splinters

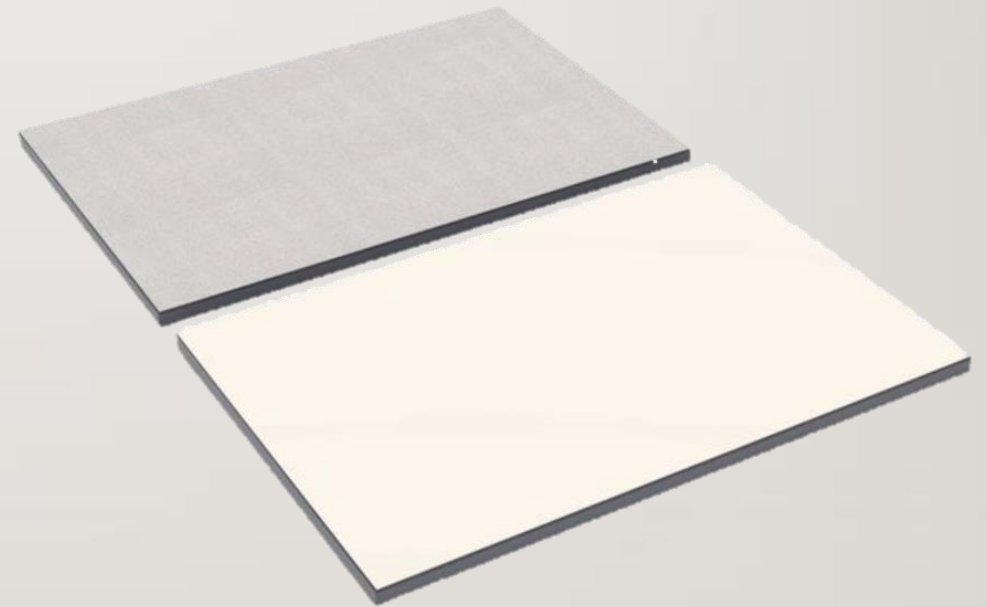

Lauren Smith

# Tabletop Support Mechanisms

- The tabletops need a mechanism to support them once lifted
  - Folding shelf bracket as the hinge and first side support
  - 80/20 swivel arm to hold up the other tabletop side

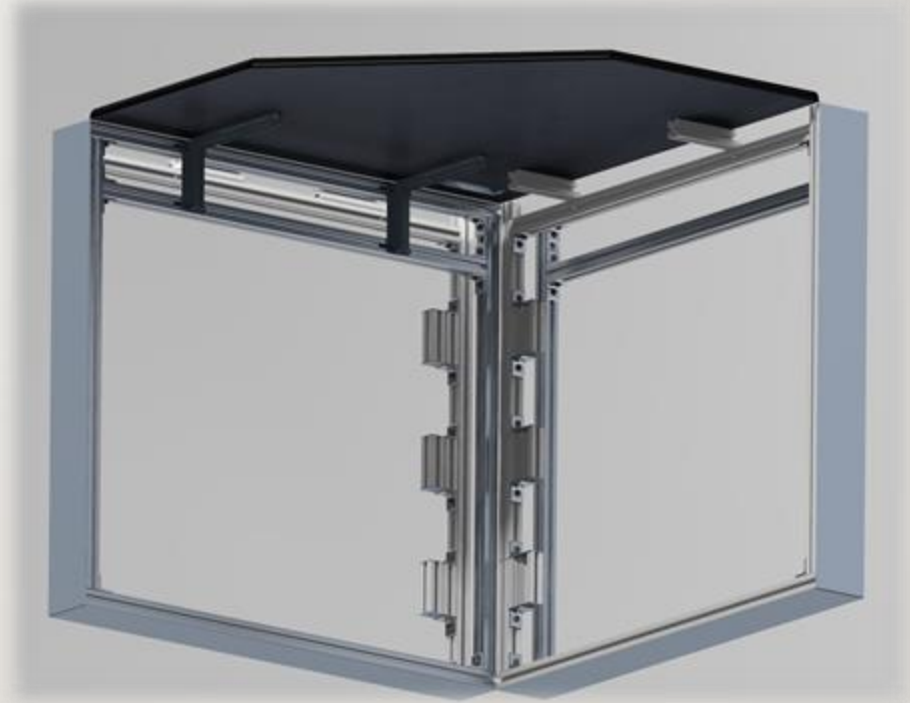
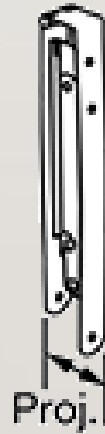
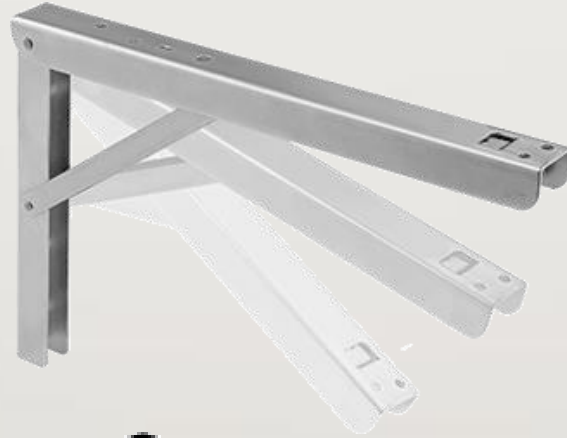

Lauren Smith

# Whiteboards

## Scissor lift

- Gas strut and spring system attached to rollers on rails
- Allows the whiteboards to be raised up with assisted lift
- Allows the dividers to be raised while seated
- Dividers are locked in the top and bottom position using spring loaded pins

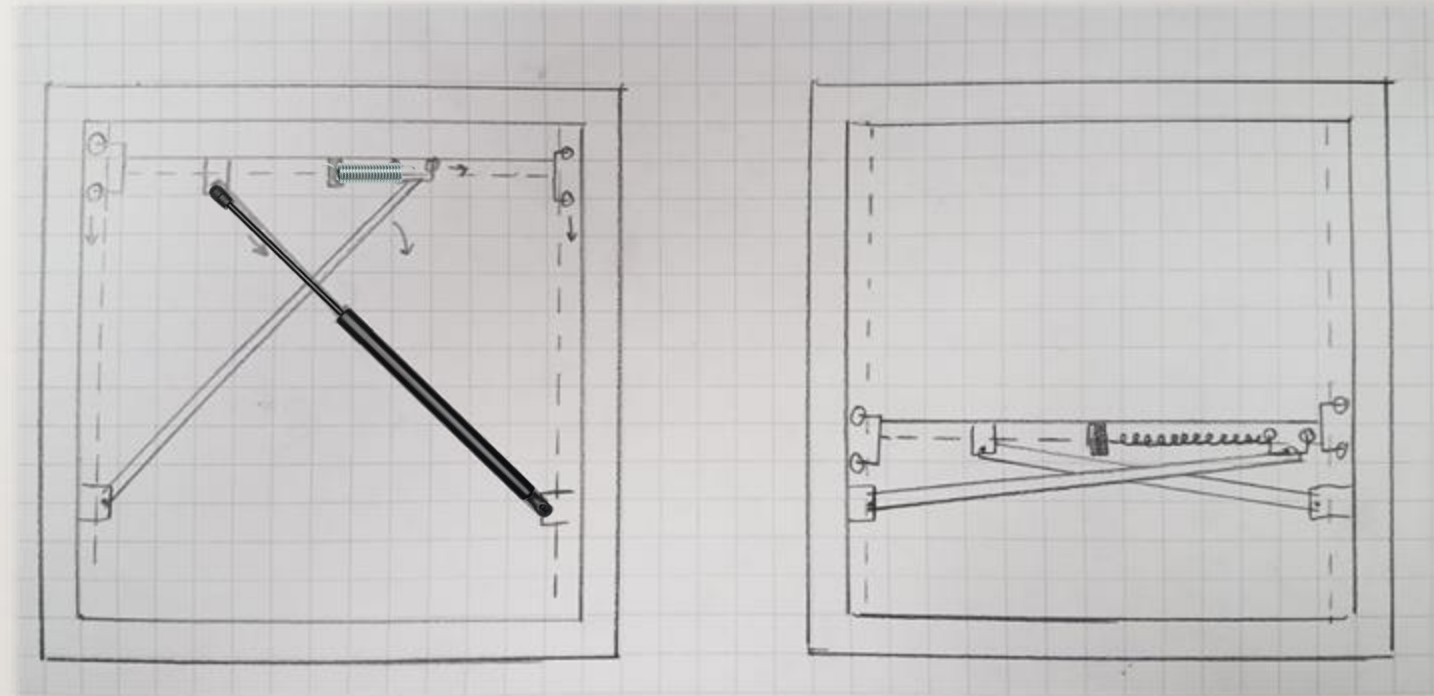

Lauren Smith



# Power Integration

- The power will be supplied to the table via a standard 120V outlet connection
- 2 outlet - 2 USB receptacle per table section, 125V 15A
- The wires will be routed down through the center of the table

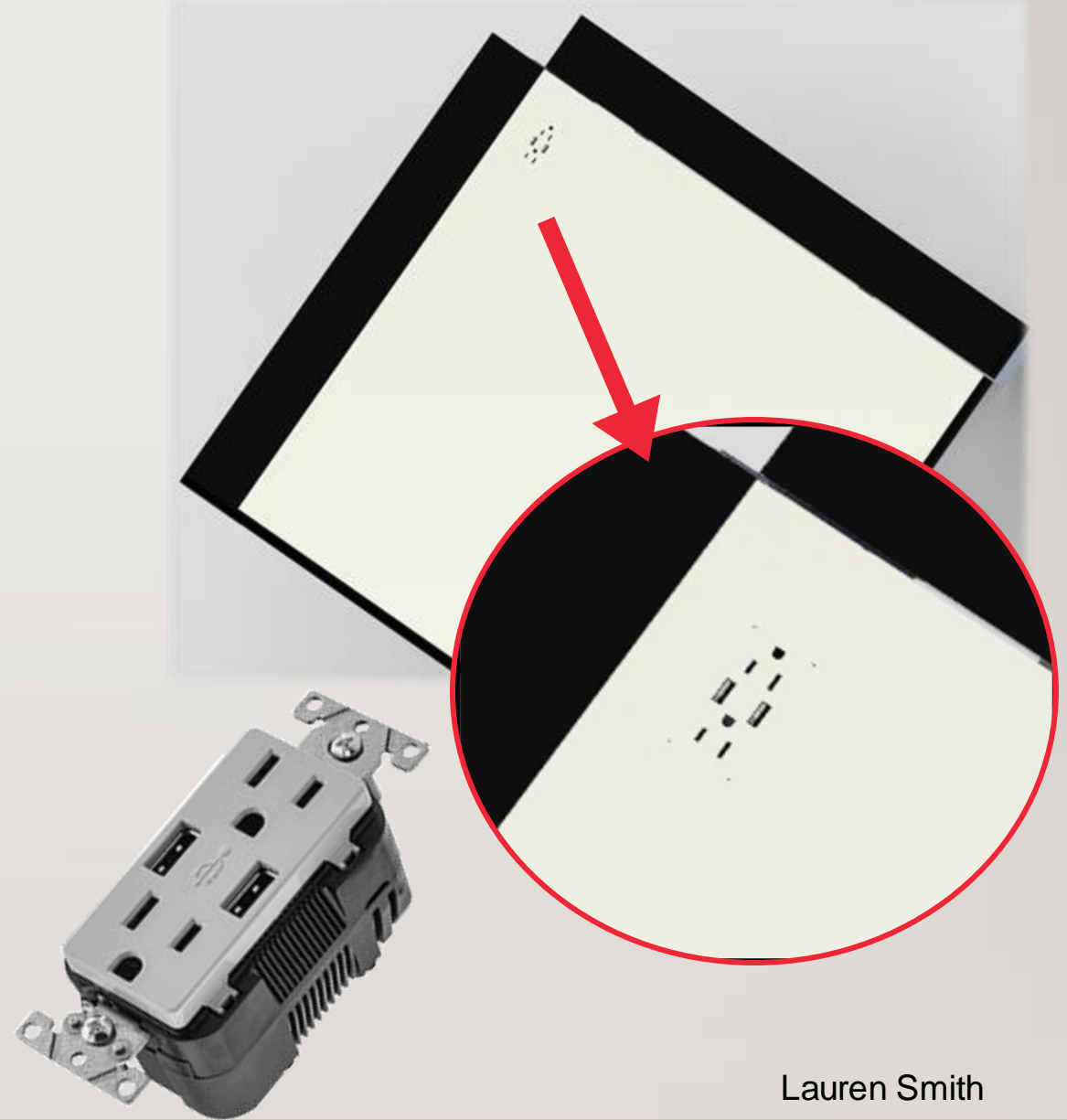

Lauren Smith

# Testing Tabletops and Whiteboards

- The tabletops will be tested by incrementally placing more weight atop until we reach our 700 lb. targeted support weight
- The whiteboards will be tested for:
  - Force needed to lift and lower
  - Functionality of the lock mechanism
- Testing will require weights of maximum increments of 50 lbs.



Lauren Smith

# Testing Power Outlet

- Receptacles will be tested with a multimeter to ensure proper current and voltage
- One laptop, one tablet, and one phone will be plugged into each receptacle to test charge speed



Lauren Smith

# Budget Report

Product Description	Quantity	Price (\$)
Aluminum T-Slotted Framing Extrusion (97 in.)	13	337.87
2-Hole Inside Corner Bracket	90	281.70
T-Nuts (Package Qty - 15)	14	85.82
Melamine Board (0.75x49x100 in.)	2	61.96
Multi-Position Fold Away Shelf Bracket	8	188.56
Straight Blade Receptacle with 2-USB Ports	4	144.28
Strap Hinge	12	31.32
	<b>Total</b>	<b>1131.51</b>

<b>Budget (\$)</b>	<b>2000.00</b>
Spent	1131.51
Remaining	868.49

Lauren Smith

# References

- 1) Barber, C. (Ed.). (2017). *Gensler Research Catalogue* (Vol. 2). Novato: ORO Editions
- 2) Free Image on Pixabay - Checklist, To Do, Activities, Boxes. (n.d.). Retrieved November 3, 2019, from <https://pixabay.com/illustrations/checklist-to-do-activities-boxes-1316848/>
- 3) <https://www.wikihow.com/Build-a-Picnic-Table>
- 4) Reynolds, S. (2013, October 24). What's the Future of 3D Printing? *Victoria and Albert Museum*
- 5) <https://formis.se/product/fallbart-bord-folding-leg/>
- 6) <https://www.bhg.com/home-improvement/electrical/how-to-test-an-electrical-receptacle/>
- 7) <https://www.thisoldhouse.com/electrical/21015625/turn-an-outlet-into-a-usb-charger>

EML4551-2

*"We are what we repeatedly  
do. Excellence, then, is not an  
act, but a habit."*

*~Aristotle*

Alec Ellis  
ace16e@my.fsu.edu

Kyle Innis  
kli15@my.fsu.edu

Anthony Muniz  
alm16c@my.fsu.edu

Rieley O'Brien  
rfo16@my.fsu.edu

Lauren Smith  
les16e@my.fsu.edu

